

Rod Ends Series K - Heavy Duty

Series GAS

Rod Ends with male thread made from free-cutting or heat-treated steel, zinc plated and fitted with a grease nipple

Especially suited for high speed applications

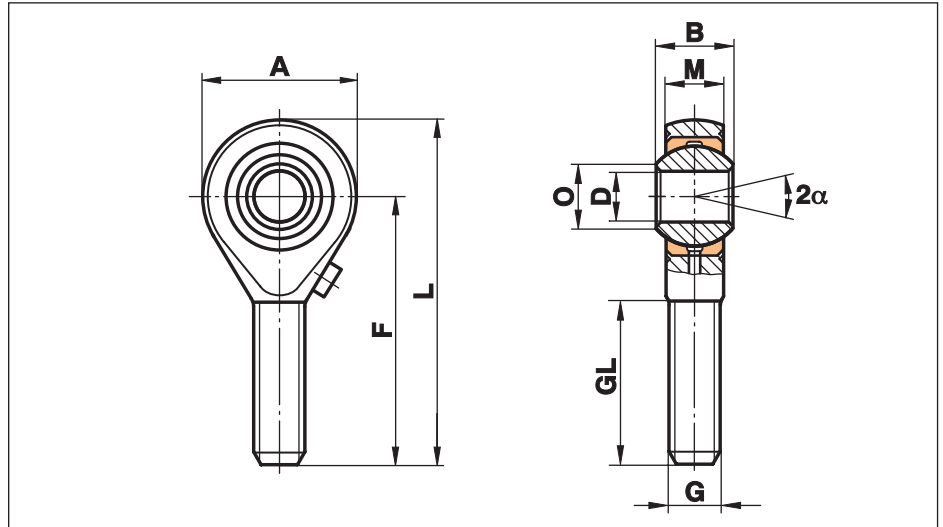

Size (D)	B	M	A	F	L	O	G	GL	Static load C ₀ kN	Dynamic load C kN	Limiting speed rev/min	Weight g
2 ¹⁾	4,5	3,60	9	20	24,5	2,6	M 2	12	0,6	1,1		3
3 ¹⁾	6,0	4,50	14	26	33,0	5,1	M 3	15	1,5	1,8		6
5 ¹⁾	8,0	6,00	18	33	42,0	7,7	M 5	20	4,3	3,3		13
6	9,0	6,75	20	36	46,0	8,9	M 6	22	6,0	4,3	1500	20
8	12,0	9,00	24	42	54,0	10,4	M 8	25	11,0	7,1	1200	33
10	14,0	10,50	28	48	62,0	12,9	M 10	29	17,4	10,0	1000	56
12	16,0	12,00	32	54	70,0	15,4	M 12	33	23,5	13,5	860	87
14	19,0	13,50	36	60	78,0	16,8	M 14	38	21,0	17,0	750	129
16	21,0	15,00	42	66	87,0	19,3	M 16	40	32,0	21,5	660	189
18	23,0	16,50	46	72	95,0	21,8	M 18x1,5	44	38,5	26,0	600	267
20	25,0	18,00	50	78	103,0	24,3	M 20x1,5	47	44,0	31,5	540	348
22	28,0	20,00	54	84	111,0	25,8	M 22x1,5	51	53,0	38,0	500	443
25	31,0	22,00	60	94	124,0	29,6	M 24x2	58	62,0	47,0	440	600
30	37,0	25,00	70	110	145,0	34,8	M 30x2	71	82,0	64,0	370	1030
35	43,0	28,00	80	125	165,0	37,7	M 36x2	73	101,0	80,0	330	1600
40	49,0	35,00	90	142	187,0	44,2	M 42x2	78	124,0	116,0	290	2550
50	60,0	45,00	116	185	243,0	55,9	M 48x2	105	308,0	185,0	230	4800

Materials:

Housing: up to size 12 turned from free-cutting steel to 9SMnPb28K, 12L13
from size 14 forged from heat-treated steel to C22, M1023
size 50 turned from heat-treated steel to C45, Aisi 1045

Insert: Special high strength bronze to CuSn8

Ball: Bearing steel to 100Cr6, Aisi 52100, hardened, ground, polished

This series is also available sealed (see page 38) or with threaded bolt (see page 39).

¹⁾ without lubrication fitting